

ASSEMBLY INSTRUCTION

AXIS Reception Counter Return

ITEM No.:AXRWN1818 & AXPRWN1818

OPTION 1 (see page 4-6)

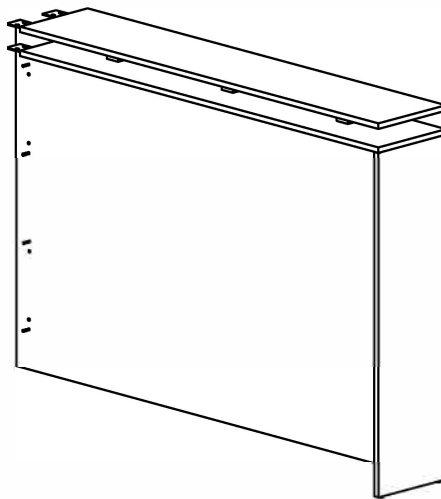

OPTION 2 (see page 7-9)

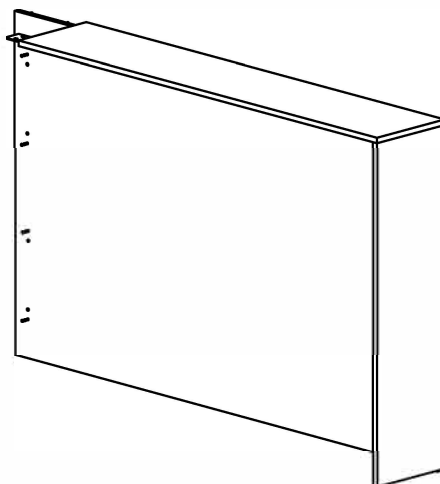

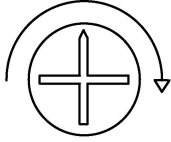

The turning direction of attaching



The arrow direction=front

Incorrect Correct

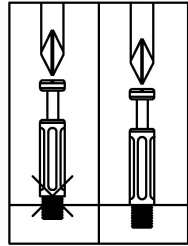

OPTION 1

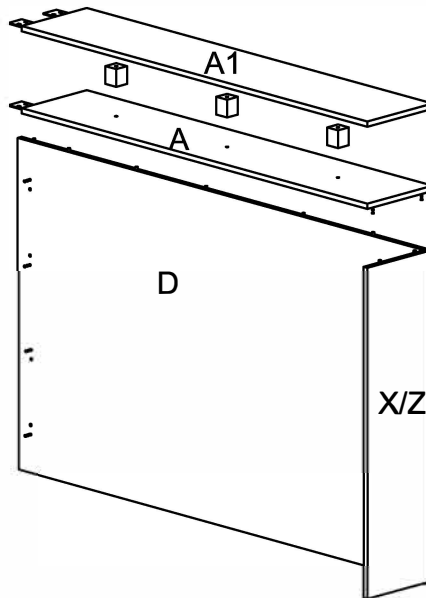

OPTION 2

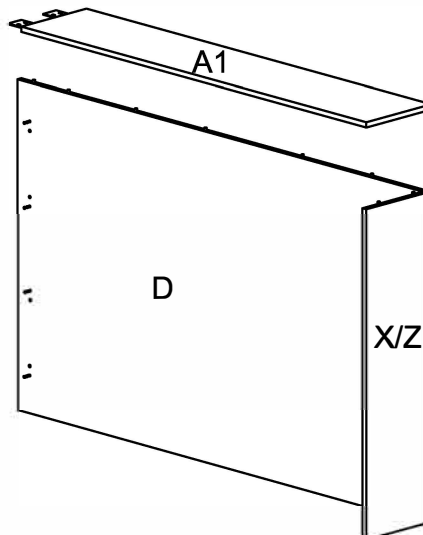

PARTS LIST

ITEM	DESCRIPTION	QTY.	ITEM	DESCRIPTION	QTY.
A1	Top panel	1	(c1)	6*35 Cam Bolt	14
A	Top panel	1	(d1)	8*30 Dowel pin	14
X/Z	Left/Right side panel	1	(c2)	(5/8") Cam Cover	14
D	Back panel	1	(p15)	Metal Stand	3
			(w1)	Washer	3
			(s20)	6*90 Hexagon Fix Bolt	3
			(s15)	Spanner	1
			(s5)	6*12 Screw	24
			(c3)	200*60 Connector	3



(c1) 6*35 Cam Bolt-14



(d1) 8*30 Dowel Pin-14



(c2) (5/8") Cam Cover-14



(p15) Metal Stand -3



(w1) Washer-3



(s20) 6*90 Hexagon Fix Bolt-3



(s15) Spanner -1



(s5) 6*12 Screw-24

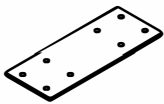

(c3) 200*60 Connector-3

Pre-installed parts

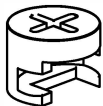

(c5) Cam



OPTION 1

STEP 1

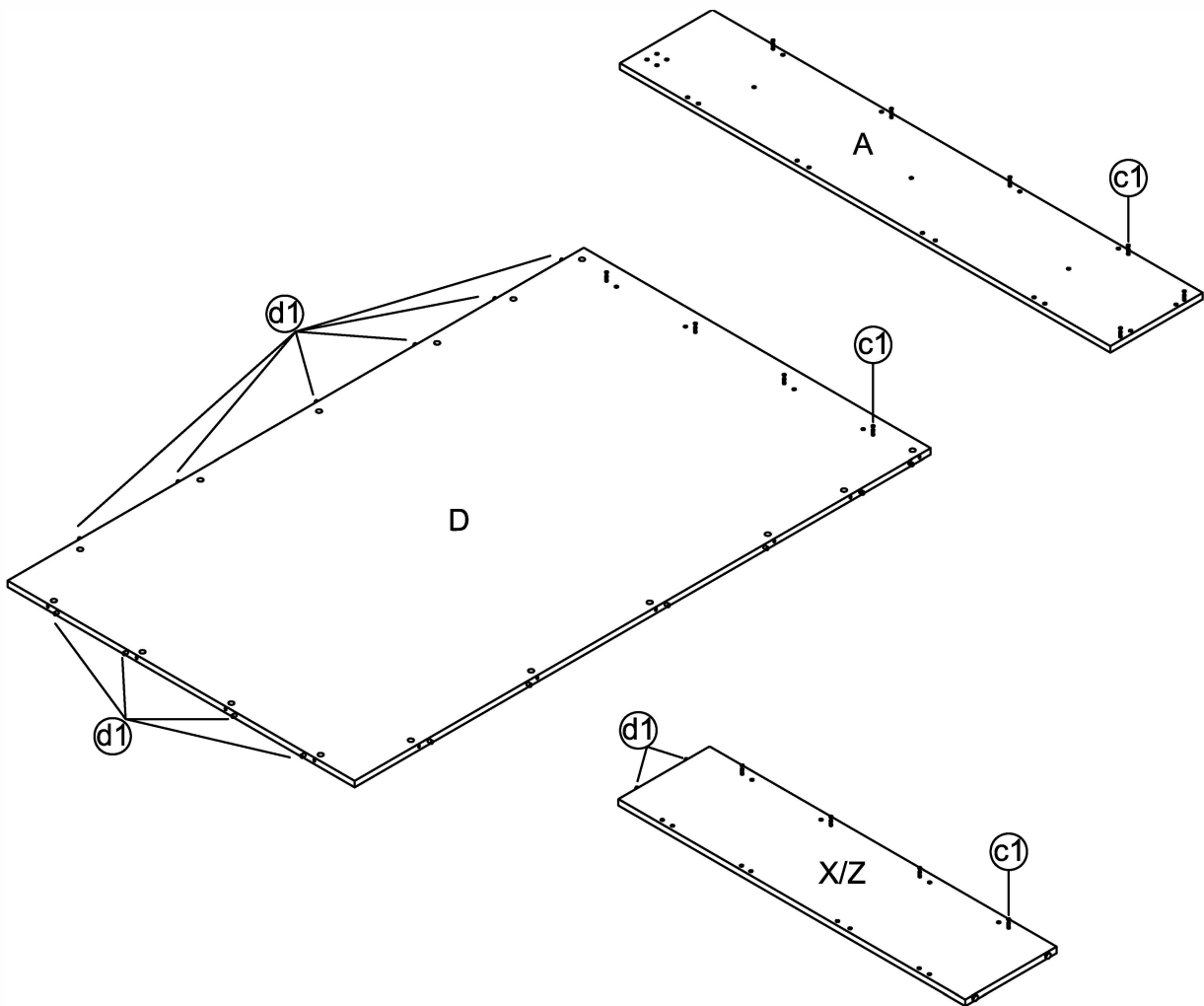

Preparation for Top panel A, Back panel D, side panel X/Z .

- 1、 Insert cam bolts (c1) and dowel pins (d1) into panels A ,D,X / Z as illustrated above.



STEP 2

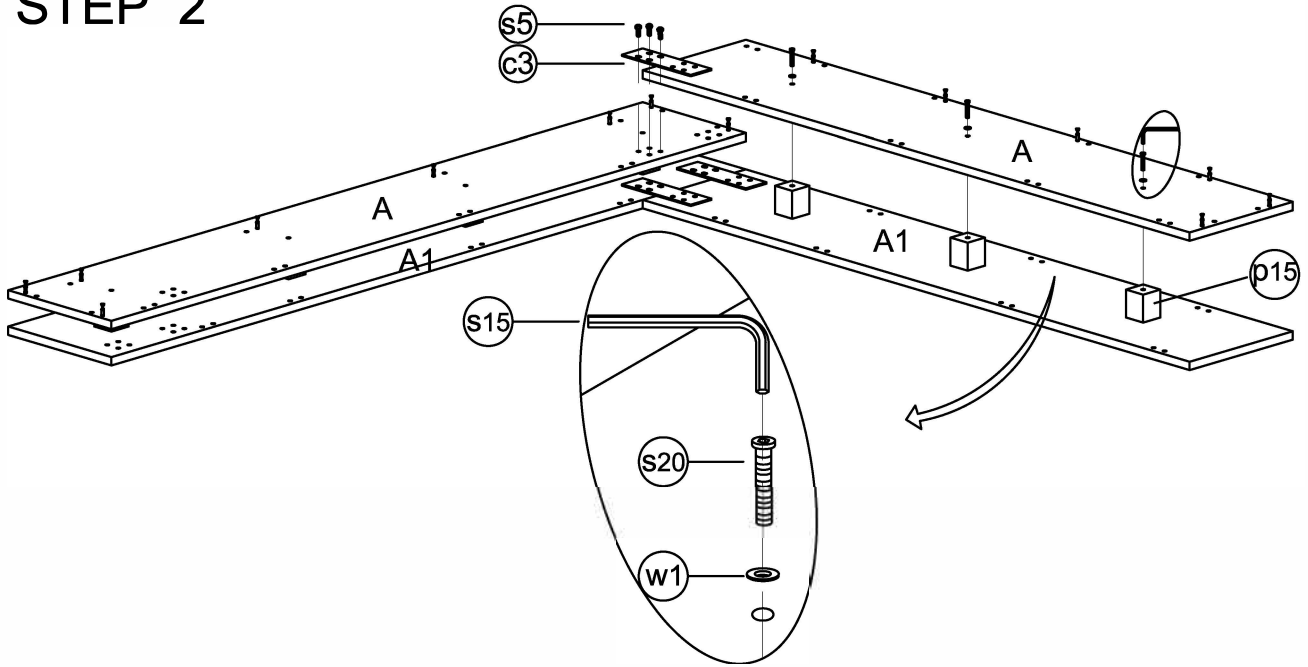

STEP 3

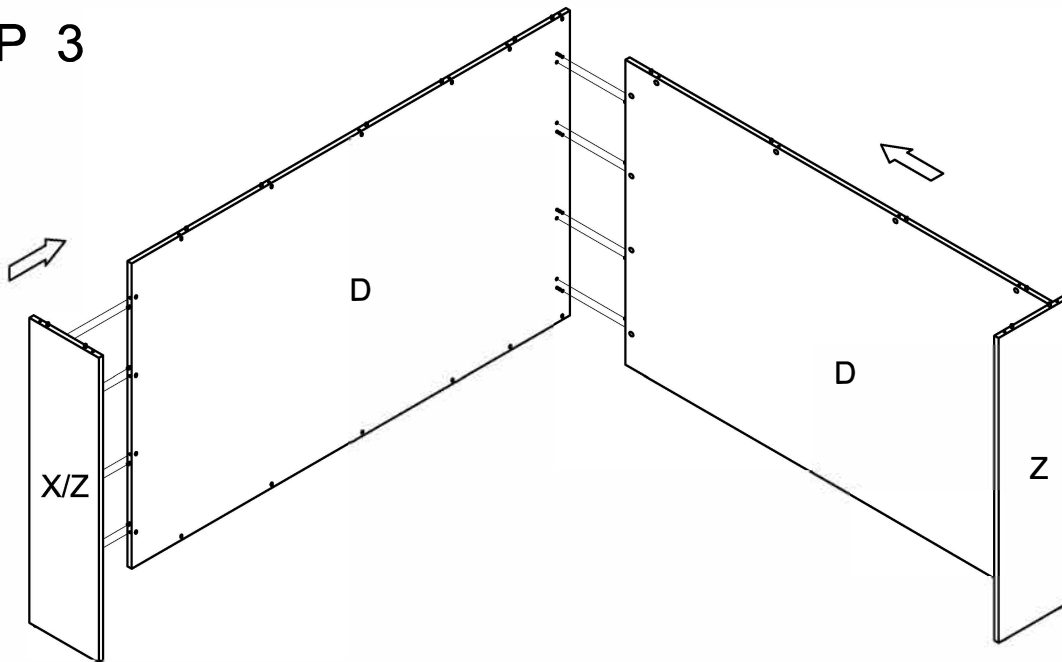



STEP 4

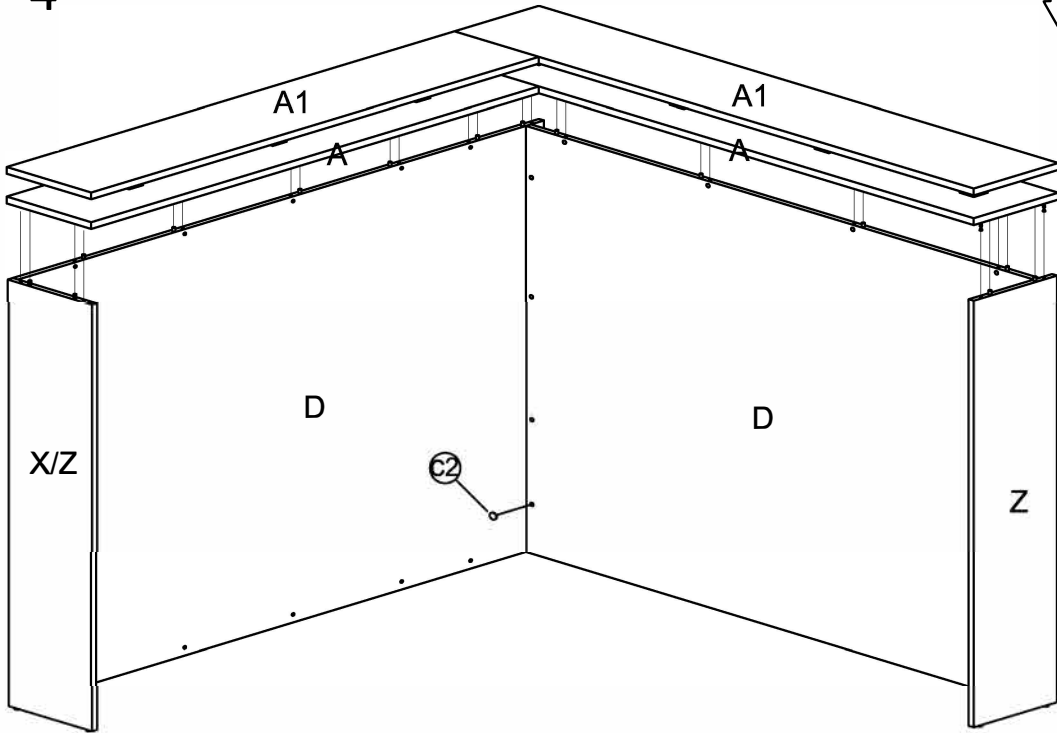

STEP 5

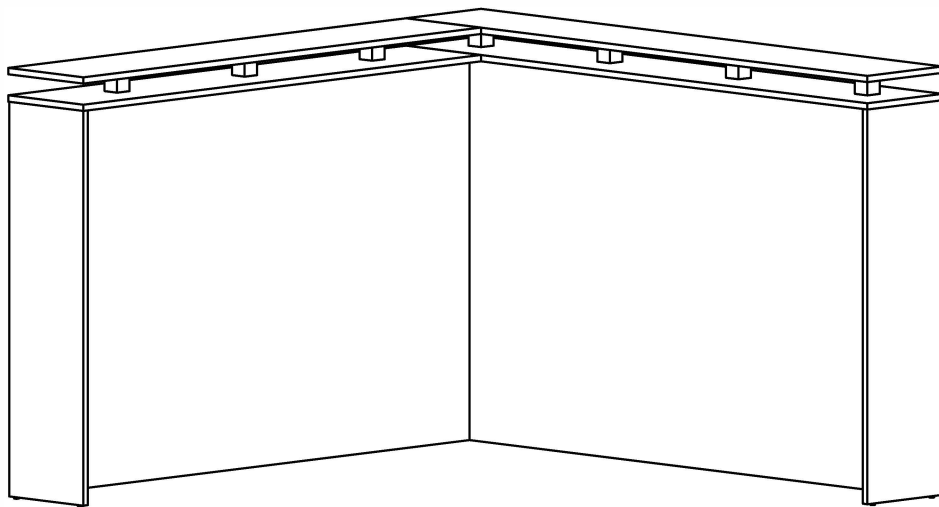



OPTION 1

STEP 1

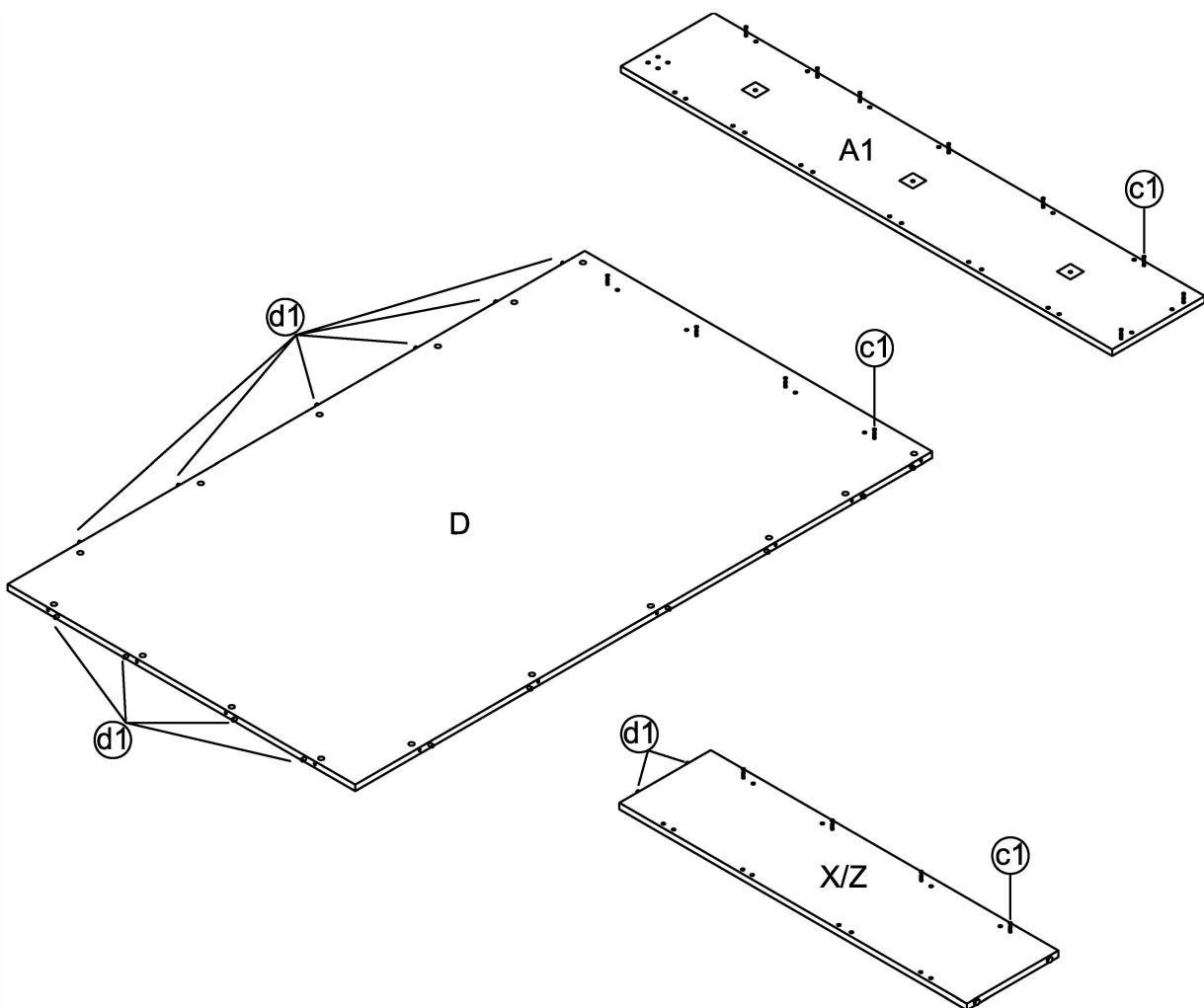

Preparation for Top panel A1, Back panel D, side panel X/Z .

- 1、 Insert cam bolts (C1) and dowel pins (d1) into panels A1 ,D,X / Z as illustrated above.

STEP 2

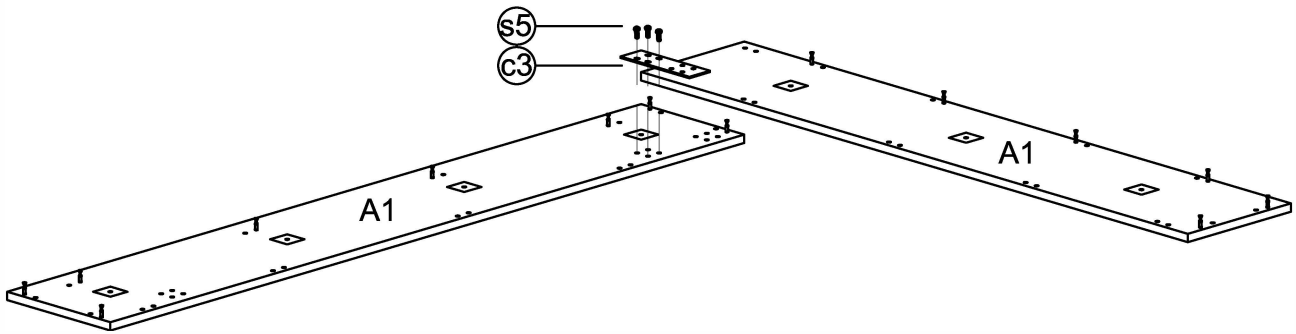

STEP 3

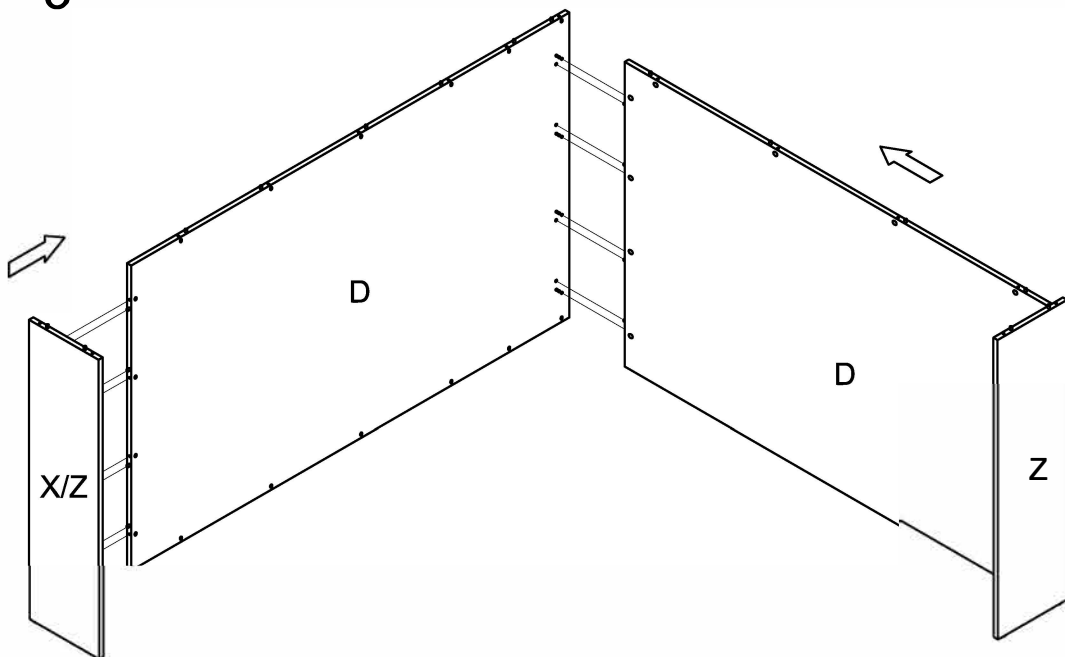



STEP 4

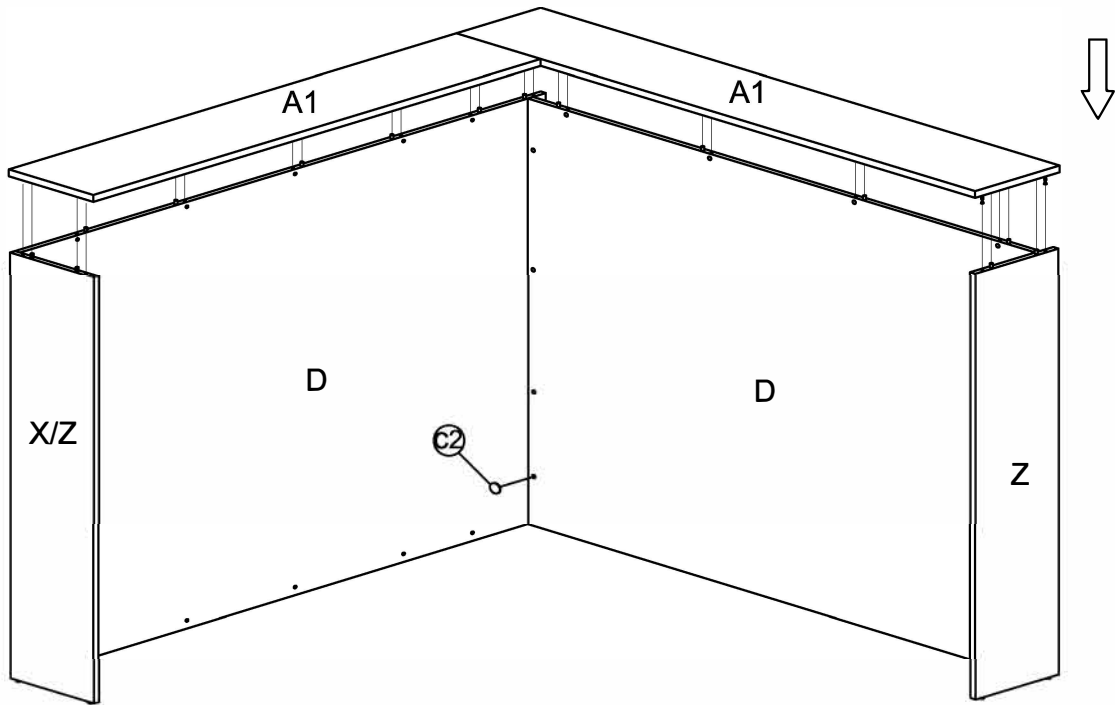

STEP 5

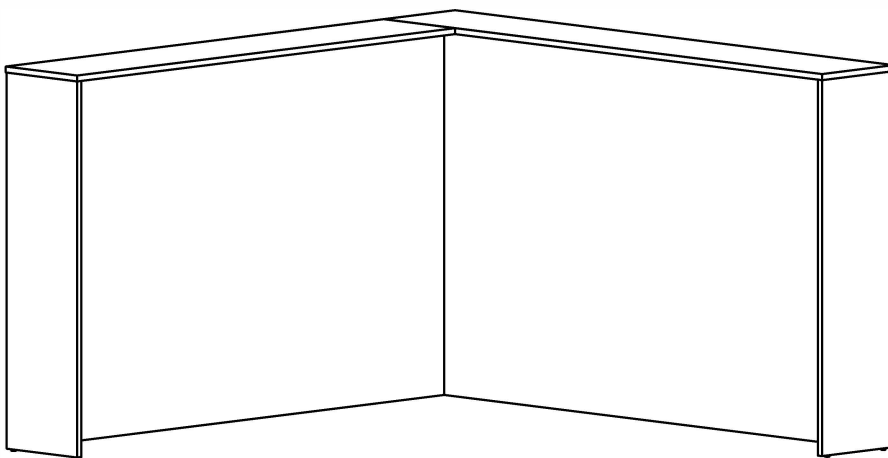

Remove all QC and panel labels and wipe clean using a damp cloth and general household cleaner .